



# ARTICULATING BOOM LIFT

## A14JE (A45JE)

### HIGHLIGHTS

LGMG A14JE electric articulating boom lifts provides environmentally friendly, zero emission operation for both indoor and outdoor applications. Up to 13.8m platform height with 1.5m standard jib, A14JE offers great ability to extend over obstacles in tight working areas.

- Zero tail swing and compact design enables easy access to tight spaces.
- Proportional control ensures smooth driving, precise positioning and comfortable operation.
- Battery powered and sealed AC drive motor provides quiet and long battery duty cycle.
- Self-leveling platform together with hydraulic platform rotation deliver exceptional productivity.
- Intelligent self-diagnostic system for quick troubleshooting.

# LGMG Electric - Articulating Boom Lift

## SPECIFICATIONS

MODELS		A14JE (A45JE)	
Measurements	Metric	US	
Working Height Max.	15.8m	51.8ft	
Platform Height	13.8m	45.3ft	
Horizontal Outreach	7.81m	25.6ft	
Up and Over Height	7.26m	23.8ft	
<b>A</b> Stowed Length	6.66m	21.9ft	
<b>B</b> Stowed Width	1.8m	5.9ft	
<b>C</b> Stowed Height	1.98m	6.5ft	
<b>D</b> Platform Length	1.83m	5.9ft	
<b>E</b> Platform Width	0.76m	2.6ft	
Platform Capacity	230kg	510lbs	
Wheelbase	2.03m	80in	
Ground Clearance	0.24m	0.79ft	

PRODUCTIVITY		
Platform Occupants Max. (in/out)	2/2	
Drive Speed-Stowed	4.8km/h	3mph
Drive Speed-Raised	1km/h	0.62mph
Gradeability-Stowed	30%	
Platform Rotator	160°	
Turnable Rotation	355°	
Turnable Tailswing	0	
Turning Radius-Inside	1.83m	6ft
Turning Radius-Outside	4.1m	13.5ft
Tires Type	Foam-filled non-marking	
Tires Size mm/in	719×246mm	28.3×9.7in

POWER	
Power Source	48V DC 390Ah
Fuel Tank Capacity	\

HYDRAULIC SYSTEM		
Hydraulic Oil Capacity	30L	7.9gal

WEIGHT		
Machine Weight(CE/ANSI)	7500kg	16535lbs

### Machines in compliant with EN280 / ANSI 92.20 Standard.

Specifications subject to change without notice. Photos and diagrams in the page are for promotional purposes only.

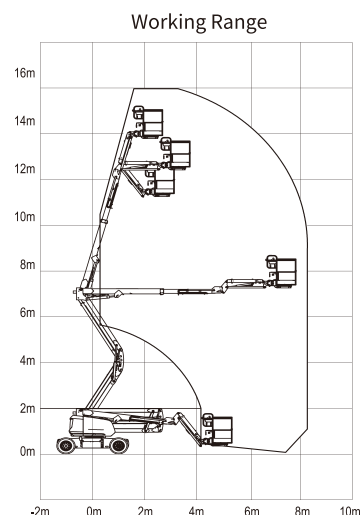
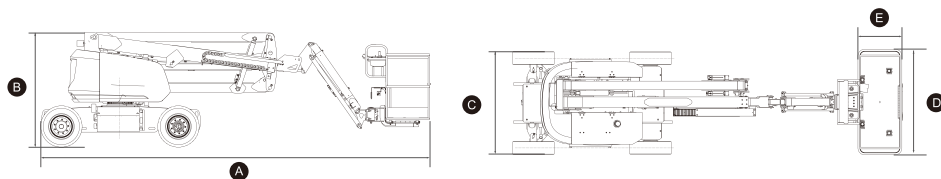

## STANDARD FEATURES

- Proportional control
- Tilt alarm with lift cut-out
- Overload sensing system
- Descent alarm with flashing beacon
- Platform auto-leveling system
- Emergency stop button
- On-board diagnostic system
- Rear-wheel drive and break
- Over tilt protection system
- Anti-crush protection
- Horn/Hour meter
- Full-height drive

## OPTIONAL

- AC power to platform
- Solid non-marking tires
- Platform tool box

2020 V1 Version

### LINGONG GROUP JINAN HEAVY MACHINERY CO., LTD.

Address: No. 2676, Kejia Road, Jinan, Shandong, China  
Email: sales@lgmg.com.cn Tel: +86-0531-67879283

### LGMG Europe B.V.

Address: Laanweg 16 3208LC Spijkenisse Rotterdam, The Netherlands

### LGMG North America, Inc.

Address: 1445 Sheffler Dr, Chambersburg, PA. 17201, USA



RELIABILITY IN ACTION